

Table of Contents

Warranty and Disclaimer	2
Introduction	3
DMX512 Output Details	4
Physical Dimensions	
Board Layout	5
Usage	
Power supply, Analog input	7
Address switch	8
Configuration jumper	9
Earth Ground	10
DMX loop through connector	11
Example input circuit	12
	13
Troubleshooting	
Ground, termination, LED	15
Some notes on DMX512	
Splitters, terminators	16
Wire type, cable length, connectors	17
Diagram of DMX 512 cable routing	18
Mini DIP address settings	1-256
	257-512
	19
	20



Warranty and Disclaimer

Warranty

Northlight Systems warrants this product against defects in materials and workmanship for a period of 1 year.

If you discover a defect, we will, at our option, repair or replace the product. We offer a full refund on the purchase price if returned in original condition in less than 30 days.

Return the product with a description of the problem. We will return your item or its replacement using the same shipping method used to ship the product originally.

Disclaimer of Liability

Northlight Systems is not responsible for any special, incidental, or consequential damages resulting for any breach of warranty, or any legal theory, including lost profits, downtime, goodwill, damage to or replacement of equipment or property, and any costs associated with the use of Northlight Systems products described herein.

Northlight Systems has a policy of continually improving our products as new technology becomes available. Northlight Systems reserves the right to make changes and improvements to the specifications of this equipment at any time without notice.

Northlight Systems has made every attempt to ensure that the information in this document is accurate and complete. Northlight Systems assumes no liability for any damages that result from the use of this manual or the equipment it documents. Northlight Systems reserves the right to make changes to this document at any time without notice.

Contact

Northlight Systems
1247 E. Valerie Drive
Tempe, AZ 85281

Voice 480 429-0577
Fax 480 949-2625

8 Channel DMX512 Encoder with DMX Merge

The Encode 8M board accepts analog 0 -10 VDC input and a DMX512 data stream from another source. The analog voltage is combined with the DMX512 input to create a single DMX512 output. The analog voltage is converted to 255 discrete levels.

Use to upgrade 0-10 volt analog lighting consoles, or add your own switches and pots to create custom controls for lighting, home or building automation.

SPECS:

DMX out: Controlled slew rate drivers, decreasing the EMI radiated from the RS485 lines, and improving signal fidelity with miterminated lines.

Analog input: 0 -10 VDC. This board expects a conditioned signal. If the encoder board is to be used in a noisy environment, external signal conditioners should be used.

DMX512 input: Accepts DMX512 digital stage lighting protocol up to 512 channels. Only DMX packets with a zero start code will be accepted. Non-zero start code packets will be ignored.

If non-zero start codes and DMX512 utilizing talk back capability is needed for other DMX receivers down stream from the Encoder, then a separate DMX through connector should be used for those devices.

Address switch: Address selection is via a 9 position mini DIP switch.

Set the starting address to the first in a group of 8.

Power requirements:

8 channel - 8 to 12 volts AC or DC @ 80 mA.

Board connections: Power and DMX output connections to the board are made via screw terminal blocks. Acceptable wire size is 18 – 24 AWG. See drawing for connector locations.

DMX output signal details:

Output is compliant with USITT's DMX512 1990 protocol.

250 Kbaud	4us/ bit
Start code:	0
Break Length:	140 us
Mark after Break	27 us
Inter frame time	29 us
Output channels	8 + start address or up to 512 using DMX512 input

Note that the timings are not as fast as the protocol allows. This should accommodate all compliant receivers.

Physical Dimensions:

2.70" X 1.30" \pm .15"

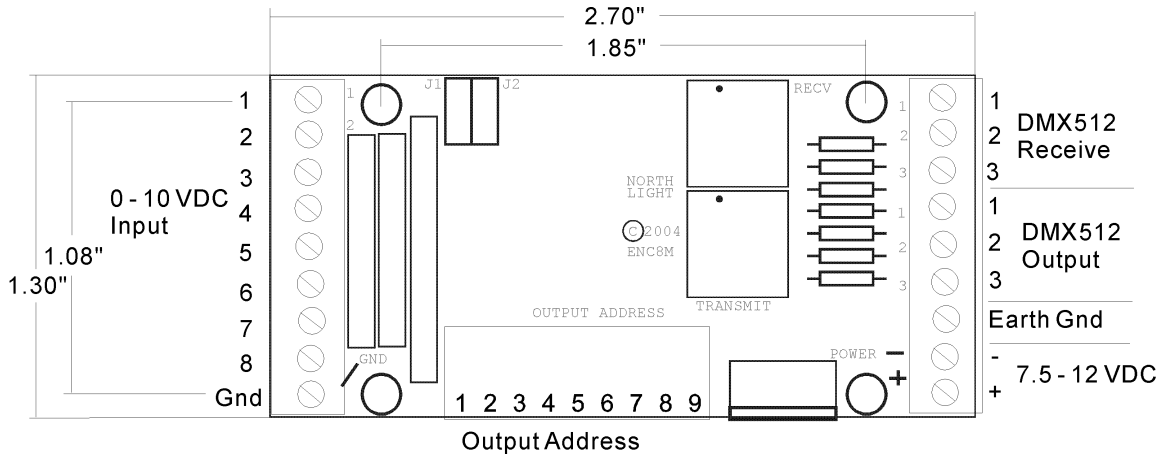

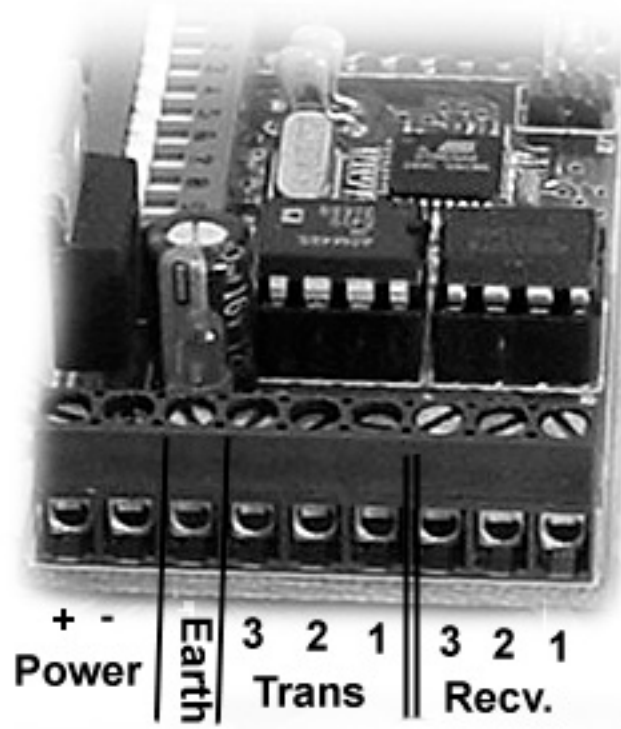
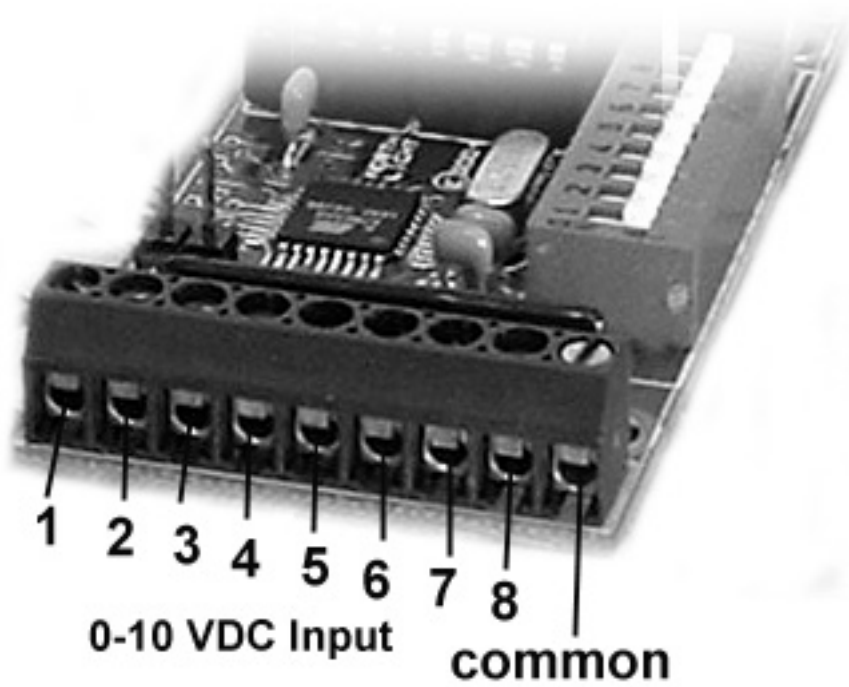

Using the Encoder

Power Input

8 to 12 volts DC.

Average idle current for the 8 channel encoder is 60 milliAmps.

The total current is based on the DMX512 load. Generally when the DMX output is terminated the current will increase by up to 15 milliAmps.

A current of 150 milliAmps should cover most situations.

Analog Inputs

Input is an analog voltage spanning 0 - 10 VDC @5mA.

This should be a smooth DC voltage with no noise or ripple. Any imperfections in the input voltage will be reflected in the DMX512 output.

DMX512 In

The DMX input pin numbers correspond to the XLR pin numbers.

The ground pin (1) is signal ground – not earth ground.

XLR pins 4 and 5 are not used.

PIN	WIRE	SIGNAL
1	shield	ground/return
2	signal	data compliment (-)
3	signal	data true (+)
4	signal	loop through(-)
5	signal	loop through(+)

Address Switch

The address switch is used to determine the starting channel of the analog input, in the DMX512 output data stream.

For example, if the start address is 1 then the analog input data will be on DMX channels 1 - 8.

A start address of 8 will output analog data on channels 8 – 15 in the DMX data stream.

The address switch has no effect on the incoming DMX512 data. The incoming DMX512 will be output in its original form except where it overlaps the analog input voltage.

When the incoming DMX and analog inputs overlap the final output will be on a highest takes precedence basis.

To avoid overlapping the incoming DMX and the analog input one would usually address the analog voltage to be output after the incoming DMX.

When using the mini DIP switch, the address is entered in the standard binary code starting with 0. See the chart of all 512-switch positions at the back of this manual.

The individual switches are numbered 1 – 9, left to right, on the switch. On the switches, Up position is off, Down is on.

Using the Configuration Jumper

There is 1 configuration jumpers used to determine how the Encoder handles the output values for the DMX512 output.

J2 – Determines the DMX output in the event of DMX receive signal loss.

Open(no jumper) – When the DMX receive is lost the Encoder will hold and continue to output the last valid data.

Closed(jumper in place) – When the DMX receive is lost, the last valid input data will be cleared after 1 second of no valid DMX. Subsequent DMX output will be zero's.

.

Earth ground connection

The DMX512 standard has changed over time from the original version

Originally, connecting pin 1 to earth ground was not specified.

The latest DMX version recommends use of earth ground referenced transmitting devices and isolated receiving devices.

Older devices that do not use a ground referenced transmitter are "legal".

The normal configuration for the Encoder is to not use the earth ground.

The Encoder is wired with the 0 volt power supply(circuit common), connected to both the receiver and transmitter.

The ground, pin 1, will be at the same potential for the receiver and transmitter.

The DC power supply should not have the 0 volt power supply connected to earth ground.

The equivalent circuit of the transmitter and receiver is shown in the figure below. The resistor values are 10 Ohms.

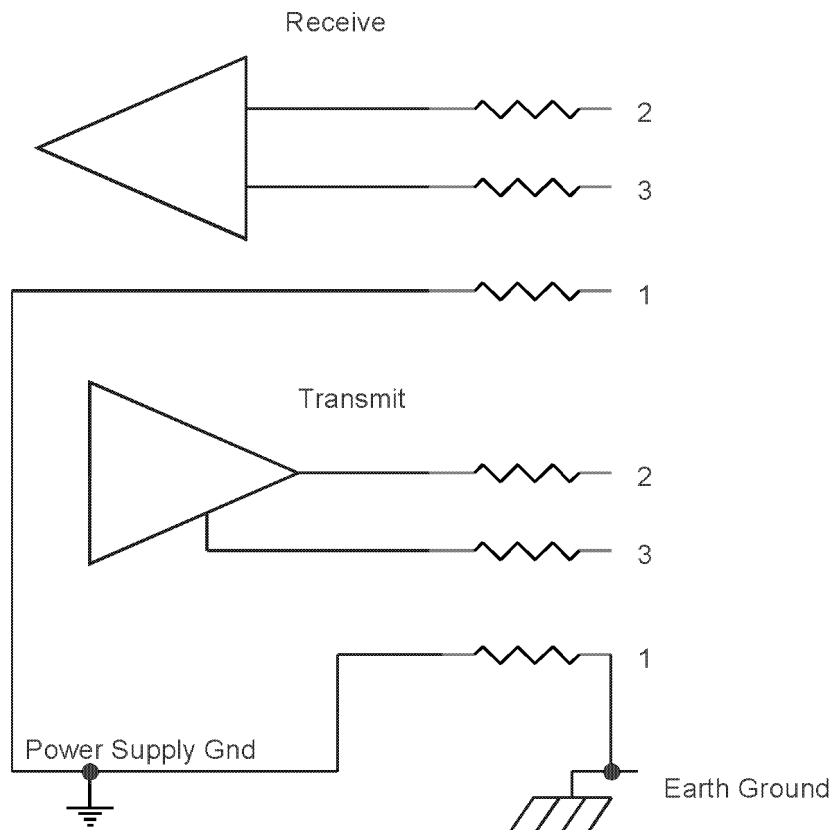

Setting up the DMX loop through connectors

The current DMX512 standards require one to provide passive loop through connectors.

The specific description is below:

Secondary data link - passive loop through ports

Devices containing two DMX512 ports, one for receive and one for transmit, ..., shall provide a direct passive link for all pins between the two ports.

Equipment designers are encouraged to provide passive loop through on Pins 4 and 5 whenever possible, even if not required.

The Encoder will not accept DMX512 with non-zero start codes and will not accept DMX512 that uses pins 4 and 5.

If devices that use non-zero start codes or pins 4 and 5 are needed then a loop through connector is required.

The drawing below shows a typical installation for a DMX512 input and loop through connection.

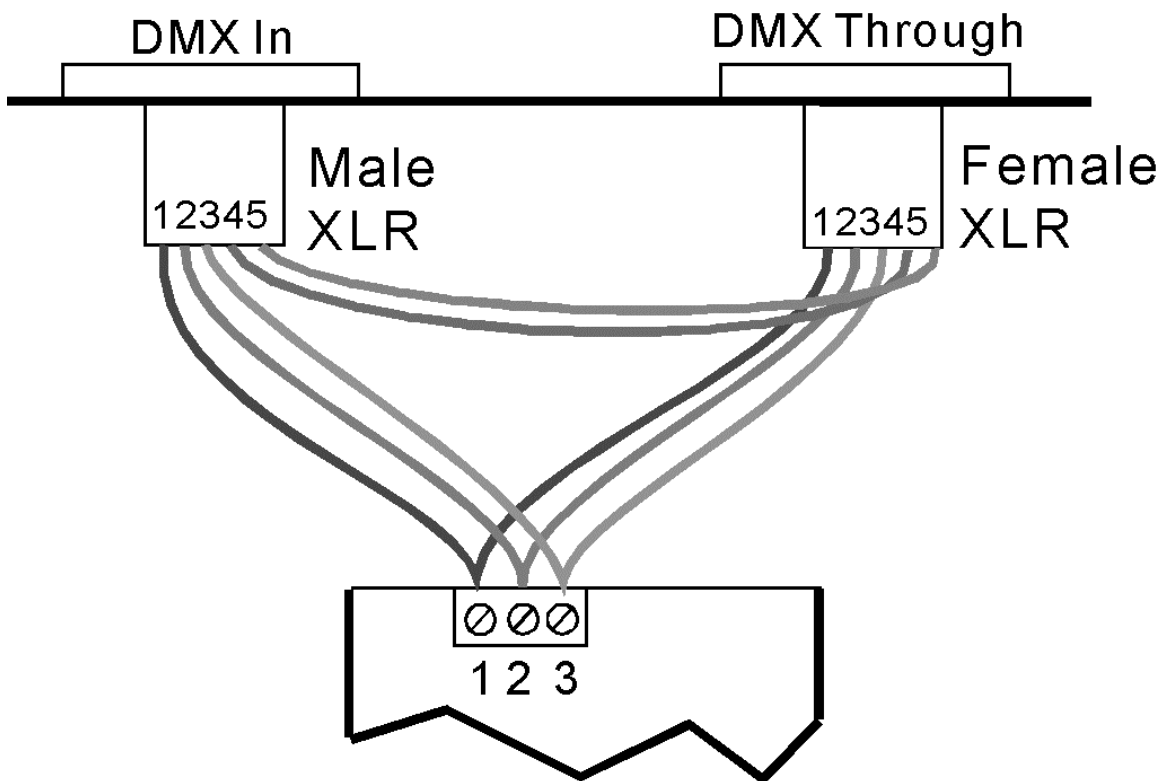

Typical input circuit

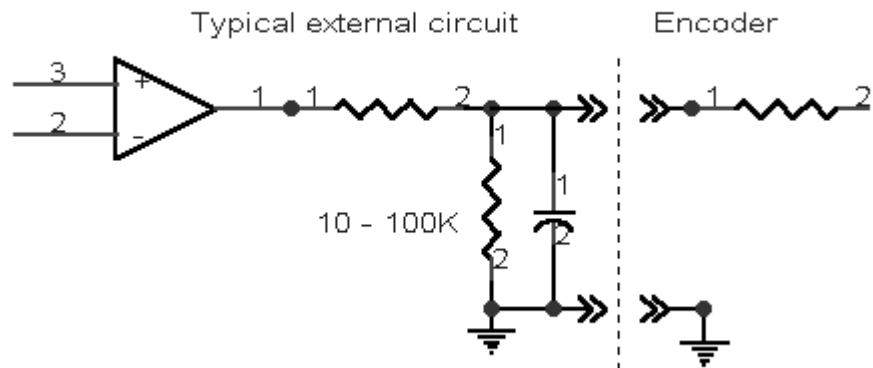
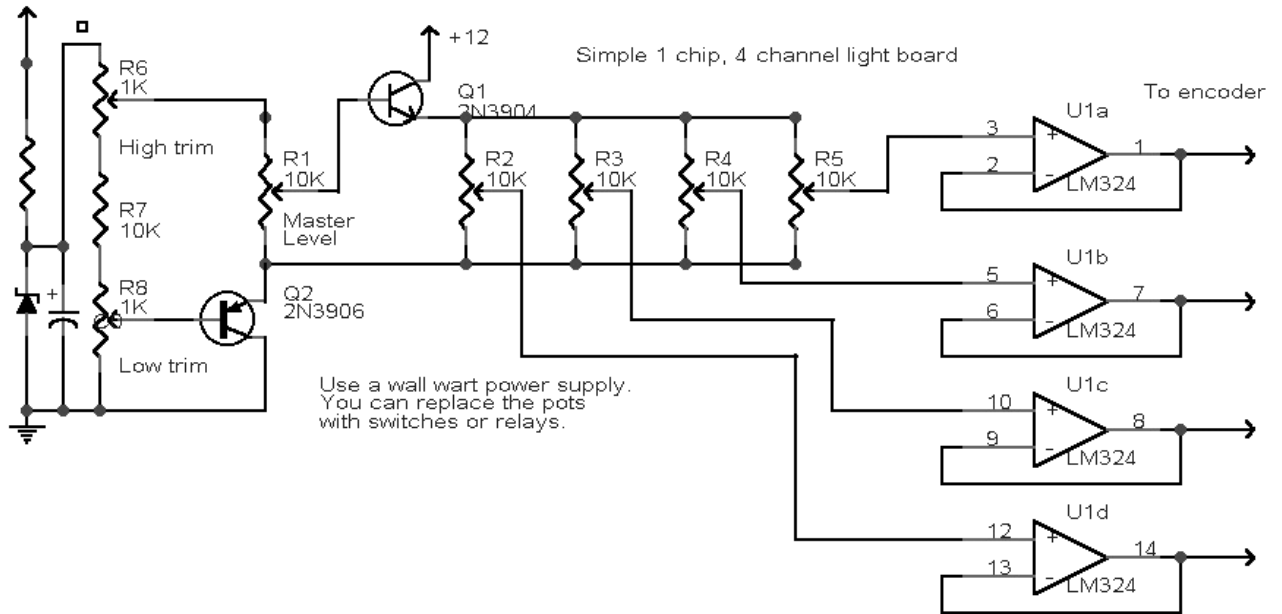

A customer sent in the schematic below. He used digital potentiometers to generate a 100 step analog voltage for input into the Encoder.

8 CHANNEL DMX RFU - INTERFACE TO NORTHLIGHT DMX ENCODER

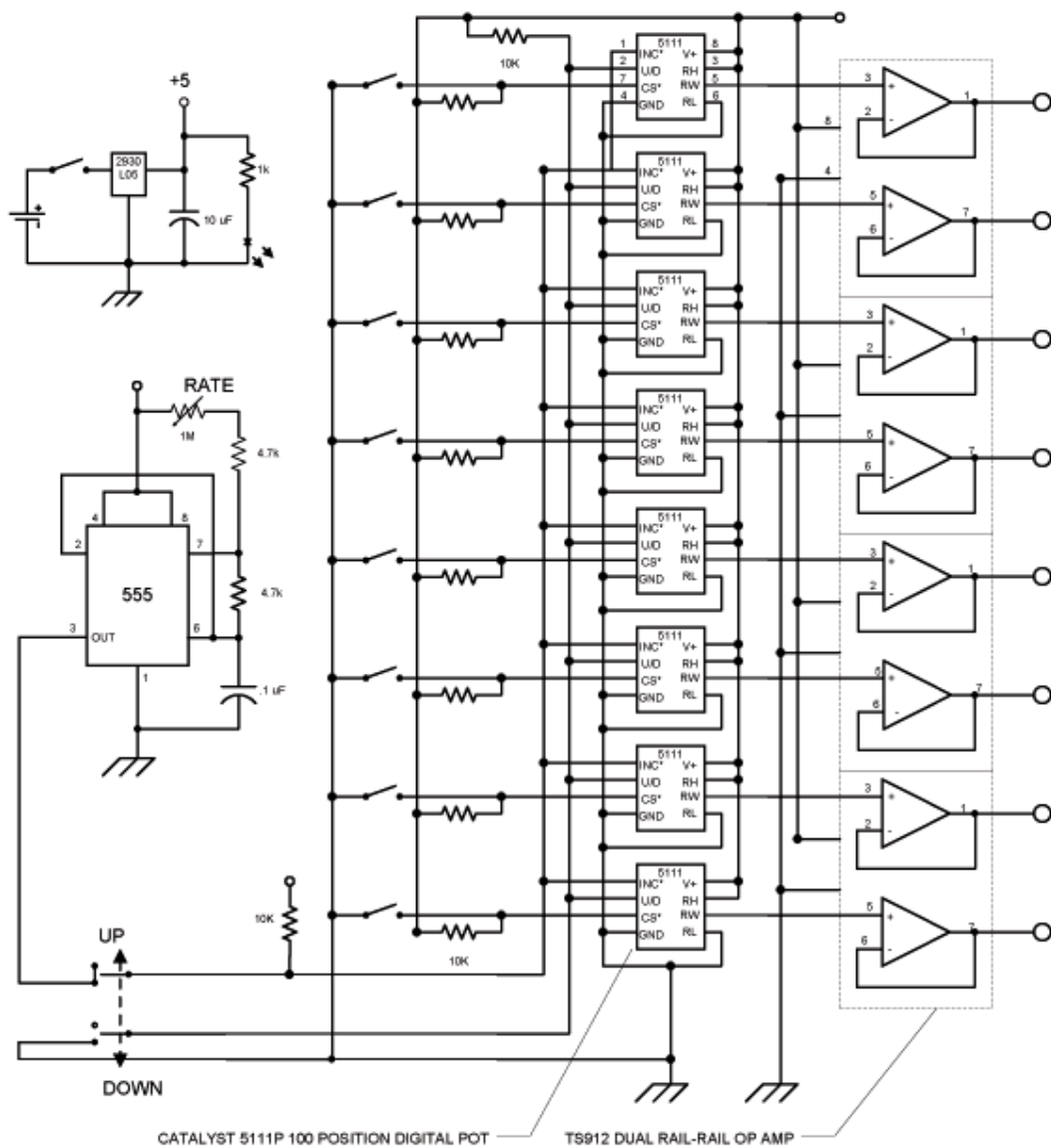

Trouble shooting

Basically the board is plug and play. There are no user adjustments. When all connections are properly made, a DMX signal, proportional to the input voltage will be present at the output pins.

Signal Ground: The input circuit signal ground, should be connected first. On the board, there is NO connection between chassis/earth ground and Signal/common ground. Do not install one.

On the DMX data cable, there is NO connection between the shield/XLR shell earth ground and the signal/common ground. Do not connect these together.

Termination: Northlight's Encoder does not contain a terminating resistor. If it is determined that a terminator is required, a 120 terminating resistor can be installed on the DMX output connector, across pins 2 – 3.

Terminators on the transmitter end are not usually required.

Terminators on the receiver are only used if the Encoder board is the last device on the DMX data link.

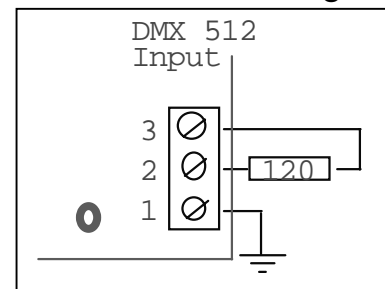

Red Power LED: If the red LED is out, the board is not getting power, or the power supply is defective.

No output: Be sure the receiver address is set to a valid address. The Encoder start address should not be higher than the receiver start address. Set all the switches OFF for testing.

Check for backward DMX input and output signal connections.

If only some inputs generate DMX, check the connections and verify the input voltage at the screw terminals with a digital voltmeter.

Erratic output: This problem can be hard to track down. First check the input signal quality and voltage. If the input voltage goes over 10 VDC, the output will drop to 0 for that channel.

Another potential problem here is the user circuit interface.

It is important that the ground from the external ground be connected first. The input maximum voltage is 10 VDC. Higher voltages may damage chips.

Misc: Good solid connections are a must. The micro screw terminals provide good connections. However the screws can be stripped by over tightening.

DMX512 signal wires should be twisted together all the way to the connector.

Some notes about DMX512

DMX 512 is a digital communications protocol that specifies a set of requirements for transmitting and receiving digital signals between lighting controllers and dimmers. There are 2 main components to this spec. The Data Protocol is the meaning of the bits and bytes that are transmitted. Northlight's Encoder is compliant with the full requirements of the Data Protocol. There is a certain amount of flexibility in the signal timing, Northlight's Encoder is capable of receiving data at the full data rate specified.

The other component of DMX512 is the Electrical Specifications. The hardware electrical specs are listed in EIA-485, commonly referred to as the RS-485 specs. The RS-485 standard, specifies only the electrical characteristics of the driver and the receiver to be used at the line interface. Northlight's Encoder is compliant with RS-485. Each Encoder represents less than 1 node load to the system.

RS485 is a data transmission system using balanced differential signals. That is 2 signal wires and signal ground. 3 wires are required.

Splitters/Repeaters

Isolation between the console and dimmers is sometimes required to prevent signal degradation and protect devices from damaging voltages on the control cable. Optically isolated splitters help avoid these problems.

Each DMX512 output can drive up to 32 devices. If there are more devices on the line, a "repeater" or "booster" is required. Some cheap devices are not fully compliant and actually represent a load equivalent to 2 or more devices.

Long or improper cables, electrically noisy environment (generators, motors) and improper use of passive "Y" splitters all contribute to DMX signal degradation. A repeater/booster may help to solve these problems.

Why ask WYE?

Wye(Y) splitters are NOT recommended for DMX512 systems. Wye splitters are simply a male inline XLR connector; parallel wired to 2 female inline XLR's. While convenient, Wye splitters cause unwanted signal reflections and possible ground loops, leading to signal degradation.

The best layout for DMX systems is a Daisy chain configuration, where the signal cable jumps from one device to the next, with no branching. Each chain can have up to 32 devices on it. When using an isolated splitter, each output can be a separate DMX daisy chain.

Termination

A common problem with DMX systems is improper termination.

A simple terminator consists of a 120 Ohm resistor connected across pins 2-3 of the DMX signal. More complex terminators utilize voltage spike protection and BI-color LED's to indicate signal integrity.

Terminators are an impedance matching circuit required to damp signals that "reflect" from the end of an improperly terminated cable, causing signal degradation under certain conditions.

On devices that have a DMX thru, a male XLR connector with terminating resistor connected across pins 2-3 and installed on the DMX thru connector will suffice. Some devices with isolated outputs will not use a terminator on the DMX out. These usually have an internal terminator that is selected with a switch.

Wire Type

There is a difference between microphone cable and “Data” cable. Sure you can get away with mic. cable for short runs in many situations. However on longer runs or marginal situations mic. cable will let you down. You may have random errors or the system won’t work at all. It comes down to insurance. If you want to insure the most reliable DMX signal distribution you need the most appropriate wire for the job. DMX512 requires wire suitable for RS-485, there is no way to get around that.

Twisted-pair cable is the most common. You can use a range of wire gauges, but the most common is 22 – 24 AWG. The characteristic impedance of the cable should be 100 to 120 Ohms.

Some other requirements are, at least 1 twisted pair plus ground and shield. It should have low capacitance and overall braid and foil shield.

Data Rate VS Cable Length

At 250K bits per second the max. cable length is about 1000 feet for DMX512 in good conditions.

Connectors

DMX512 protocol specifies that 5 pin XLR connectors are used. Female on the transmitter and male on the receiver.

When a 3 pin XLR is used it is wired the same as the first 3 pins on the 5 pin XLR.

PIN	WIRE	SIGNAL
1	shield	ground/return
2	signal	data compliment (-)
3	signal	data true (+)
4	signal	spare data compliment (-)
5	signal conductor	spare data true (+)

Conductors 2/3 and 4/5 should be twisted together.

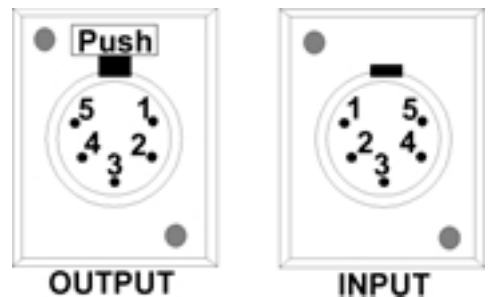

Typical DMX signal routing

Simple setup

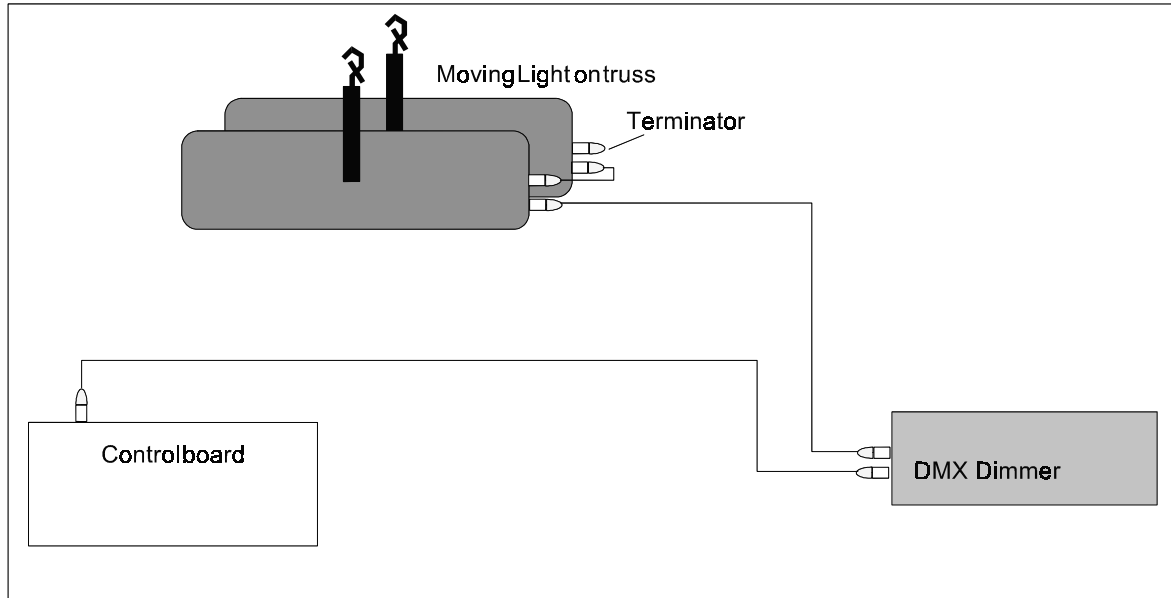

A more complicated setup. The Isolated splitter greatly simplifies cable routing and keeps individual runs short.

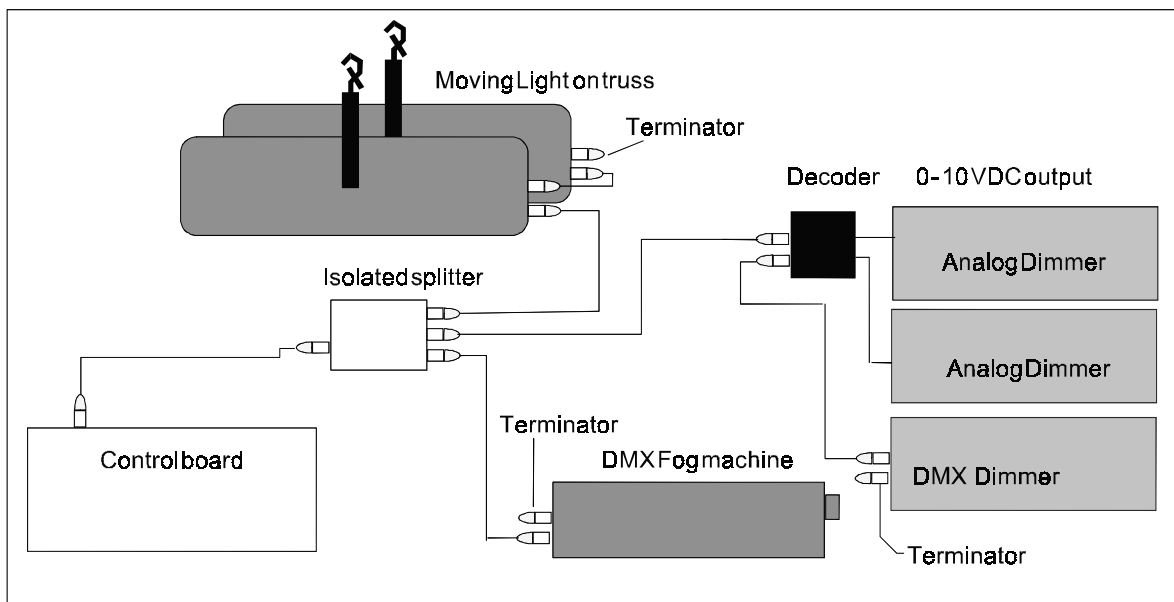

Encode 8M

Ch# Dip Switch On	Ch# Dip Switch On	Ch# Dip Switch On	Ch# Dip Switch On
1 = 0	65= 7	129 = 8	193 = 7,8
2 = 1	66= 1,7	130 = 1,8	194 = 1,7,8,
3 = 2	67= 2,7	131 = 2,8	195 = 2,7,8,
4 = 1,2	68= 1,2,7	132 = 1,2,8	196 = 1,2,7,8
5 = 3	69= 3,7	133 = 3,8	197 = 3,7,8
6 = 1,3	70= 1,3,7	134 = 1,3,8	198 = 1,3,7,8
7 = 2,3	71= 2,3,7	135 = 2,3,8	199 = 2,3,7,8
8 = 1,2,3	72= 1,2,3,7	136 = 1,2,3,8	200 = 1,2,3,7,8
9 = 4	73= 4,7	137 = 4,8	201 = 4,7,8,
10 = 1, 4	74= 1,4,7	138 = 1,4,8	202 = 1,4,7,8
11 = 2,4	75= 2,4,7	139 = 2,4,8	203 = 2,4,7,8
12 = 1,2,4	76= 1,2,4,7	140 = 1,2,4,8	204 = 1,2,4,7,S
13 = 3,4	77= 3,4,7	141 = 3,4,8	205 = 3,4,7,8
14 = 1,3,4	78= 1,3,4,7	142 = 1,3,4,8	206 = 1,3,4,7,8
15 = 2,3,4	79= 2,3,4,7	143 = 2,3,4,8	207 = 2,3,4,7,8
16 = 1,2,3,4	80= 1,3,4,7	144 =1,2,3,4,8	208 = 1,2,3,4,7,8
17 = 5	81= 5,7	145 = 5,8	209 = 5,7,8
18 = 1,5	82= 1,5,7	146 = 1,5,8	210 = 1,5,7,8
19 = 2, 5	83= 2,5,7	147 = 2,5,8	211= 2, 5,7,8
20 = 1,2,5	84= 1,2,5,7	148 = 1,2,5,8	212 = 1,2,5,7,8
21 = 3,5	85= 3,5,7	149 = 3,5,8	213 = 3,5,7,8
22 = 1,3,5	86= 1,3,5,7	150 = 1,3,5,8	214 = 1,3,5,7,8
23 = 2,3,5	87= 2,3,5,7	151 = 2,3,5,8	215 = 2,3,5,7,8
24 = 1,2,3,5	88= 1,2,3,5,7	152 = 1,2,3,5,8	216 = 1,2,3,5,7,8
25 = 4,5	89= 4,5,7	153 = 4,5,8	217 = 4, 5,7, 8
26 = 1,4,5	90= 1,4,5,7	154 = 1,4,5,8	218 = 1,4,5,7,S
27 = 2,4,5	91= 2,4,5,7	155 =2,4,5,8	219 = 2,4,5,7,8
28 = 1,2,4,5	92= 1,2,4,5,7	156 = 1,2,4,5,8	220 = 1,2,4,5,7,8
29 = 3,4,5	93= 3,4,5,7	157 = 3,4,5,8	221 = 3,4,5,7,8
30 = 1,3,4,5	94= 1, 3,4,5,7	158 = 1,3,4,5,8	222 = 1,3,4,5,7,8
31 = 2,3,4,5	95= 2,3,4,5,7	159 = 2,3,4,5,8	223 = 2,3,4,5,7,8
32 = 1,2,3,4,5	96= 1,2,3,4,5,7	160 = 1,2,3,4,5,8	224 = 1,2,3,4,5,7,8
33 = 6	97= 1,6,7	161 = 6,8	225 = 6,7,8
34 = 1,6	98 = 1,6,7	162 = 1,6,8	226 = 1,6,7,8
35 = 2,6	99 = 2,6,7	163 =2,6,8	227 = 2,6,7,8
36 = 1,2,6	100 = 1,2,6,7	164 =1,2,6,8	228 = 1,2,6,7,8
37 = 3,6	101 = 3,6,7	165 =3,6,8	229 = 3,6,7,8
38 = 1,3,6	102 = 1,3,6,7	166 = 1,3,6,8	230 = 1,3,6,7,8
39 = 2,3,6	103 = 2,3,6,7	167 = 2,3,6,8	231 = 2,3,6,7,8
40 = 1,2,3,6	104 = 1,2,3,6,7	168 = 1,2,3,6,8	232 = 1,2,3,6,7,8
41 = 4,6	105 = 4,6,7	169 = 4,6,8	233 = 4,6,7,8
42 = 1,4,6	106 = 1,4,6,7	170 = 1,4,6,8	234 = 1,4,6,7,8
43 = 2,4,6,	107 = 2,4,6,7	171 = 2,4,6,S	235 = 2,4,6,7,S
44 = 1,2,4,6	108 = 1,2,4,6,7	172 = 1,2,4,6,8	236 = 1,2,4,6,7,8
45 = 3,4,6	109 = 3,4,6,7	173 = 3,4,6,8	237 = 3,4,6,7,8
46 = 1,3,4,6	110 = 1,3,4,6,7	174 = 1,3,4,6,8	238 = 1,3,4,6,7,8
47 = 2,3,4,6	111 = 2,3,4,6,7	175 = 2,3,4,6,8	239 = 2,3,4,6,7,8
48 = 1,2,3,4,6	112 = 1,2,3,4,6,7	176 = 1,2,3,4,6,8	240 = 1,2,3,4,6,7,8
49 = 5,6	113 = 5,6,7	177 = 5,6,8	241 = 5,6,7,8
50 = 1,5,6	114 = 1,5,6,7	178 = 1,5,6,8	242 = 1,5,6,7,8
51 = 2,5,6	115 = 2,5,6,7	179 = 2,5,6,8	243 = 2,5,6,7,8
52 = 1,2,5,6	116 = 1,2,5,6,7	180 = 1,2,5,6,8	244 = 1,2,5,6,7,8
53 = 3,5,6	117 = 3,5,6,7	181 = 3,5,6,8	245 = 3,5,6,7,8
54 = 1,3,5,6	118 = 1,3,5,6,7	182 = 1,3,5,6,8	246 = 1,3,5,6,7,8
55 = 2,3,5,6	119 = 2,3,5,6,7	183 = 2,3,5,6,8	247 = 2,3,5,6,7,8
56 = 1,2,3,5,6	120 = 1,2,3,5,6,7	184 = 1,2,3,5,6,8	248 = 1,2,3,5,6,7,8
57 = 4,5,6	121 = 4,5,6,7	185 = 4,5,6,8	249 = 4,5,6,7,8
58 = 1,4,5,6	122 = 1,4,5,6,7	186 = 1,4,5,6,8	250 = 1,4,5,6,7,8
59 = 2,4,5,6	123 = 2,4,5,6,7	187 = 2,4,5,6,8	251 = 2,4,5,6,7,8
60 = 1,2,4,5,6	124 = 1,2,4,5,6,7	188 = 1,2,4,5,6,8	252 = 1,2,4,5,6,7,8
61 = 3,4,5,6	125 = 3,4,5,6,7	189 = 3,4,5,6,8	253 = 3,4,5,6,7,8
62 = 1,3,4,5,6	126 = 1,3,4,5,6,7	190 = 1,3,4,5,6,8	254 = 1,3,4,5,6,7,8
63 = 2,3,4,5,6	127 = 2,3,4,5,6,7	191 = 2,3,4,5,6,8	255 = 2,3,4,5,6,7,8
64 = 1,2,3,4,5,6	128 = 1,2,3,4,5,6,7	192 = 1,2,3,4,5,6,8	256 = 1,2,3,4,5,6,7,8

NORTHLIGHT SYSTEMS

Ch#	Dip Switch On	Ch#	Dip Switch On	Ch#	Dip Switch On	Ch#	Dip Switch On
257	= 9	321	= 7,9	385	= 8,9	449	= 7,8,9
258	= 1,9	322	= 1,7,9	386	= 1,8,9	450	= 1,7,8,9
259	= 2,9	323	= 2,7,9	387	= 2,8,9	451	= 2,7,8,9
260	= 1,2,9	324	= 1,2,7,9	388	= 1,2,8,9	452	= 1,2,7,8,9
261	= 3,9	325	= 3,7,9	389	= 3,8,9	453	= 3,7,8,9
262	= 1,3,9	326	= 1,3,7,9	390	= 1,3,8,9	454	= 1,3,7,8,9
263	= 2,3,9	327	= 2,3,7,9	391	= 2,3,8,9	455	= 2,3,7,8,9
264	= 1,2,3,9	328	= 1,2,3,7,9	392	= 1,2,3,8,9	456	= 1,2,3,7,8,9
265	= 4,9	329	= 4,7,9	393	= 4,8,9	457	= 4,7,8,9
266	= 1, 4, 9	330	= 1,4,7,9	394	= 1,4,8,9	458	= 1,4,7,8,9
267	= 2,4,9	331	= 2,4,7,9	395	= 2,4,8,9	459	= 2,4,7,8,9
268	= 1,2,4,9	332	= 1,2,4,7,9	396	= 1,2,4,8,9	460	= 1,2,4,7,8,9
269	= 3,4,9	333	= 3,4,7, 9	397	= 3,4,8,9	461	= 3,4,7,8,9
270	= 1,3,4,9	334	= 1,3,4,7,9	398	= 1,3,4,8,9	462	= 1,3,4,7,8,9
271	= 2,3,4,9	335	= 2,3,4,7,9	399	= 2,3,4,8,9	463	= 2,3,4,7,8,9
272	= 1,2,3,4,9	336	= 1,2,3,4,7,9	400	= 1,2,3,4,8,9	464	= 1,2,3,4,7,8,9
273	= 5,9	337	= 5,7,9	401	= 5,8,9	465	= 5,7,8,9
274	= 1,5,9	338	= 1,5,7,9	402	= 1,5,8,9	466	= 1,5,7,8,9
275	= 2, 5, 9	339	= 2,5,7,9	403	= 2,5,8,9	467	= 2,5,7,8,9
276	= 1,2,5,9	340	= 1,2,5,7,9	404	= 1,2,5,8,9	468	= 1,2,5,7,8,9
277	= 3,5,9	341	= 3,5,7,9	405	= 3,5,8,9	469	= 3,5,7,8,9
278	= 1,3,5,9	342	= 1,3,5,7,9	406	= 1,3,5,8,9	470	= 1,3,5,7,8,9
279	= 2,3,5,9	343	= 2,3,5,7,9	407	= 2,3,5,8,9	471	= 2,3,5,7,8,9
280	= 1,2,3,5,9	344	= 1,2,3,5,7,9	408	= 1,2,3,5,8,9	472	= 1,2,3,5,7,8,9
281	= 4,5,9	345	= 4,5,7,9	409	= 4,5,8,9	473	= 4,5,7,8,9
282	= 1,4,5,9	346	= 1,4,5,7,9	410	= 1,4,5,8,9	474	= 1,4,5,7,8,9
283	= 2,4,5,9	347	= 2,4,5,7,9	411	= 2,4,5,8,9	475	= 2,4,5,7,8,9
284	= 1,2,4,5,9	34B	= 1,2,4,5,7,9	412	= 1,2,4,5,8,9	476	= 1,2,4,5,7,8,9
285	= 3,4,5,9	349	= 3,4,5,7,9	413	= 3,4,5,8,9	477	= 3,4,5,7,8,9
286	= 1,3,4,5,9	350	= 1,3,4,5,7,9	414	= 1,3,4,5,8,9	478	= 1,3,4,5,7,8,9
287	= 2,3,4,5,9	351	= 2,3,4,5,7,9	415	= 2,3,4,5,8,9	479	= 2,3,4,5,7,8,9
288	= 1,2,3,4,5,9	352	= 1,2,3,4,5,7,9	416	= 1,2,3,4,5,8,9	480	= 1,2,3,4,5,7,8,9
289	= 6,9	353	= 6,7,9	477	= 6,8,9	481	= 6,7,8,9
290	= 1,6,9	354	= 1,6,7,9	418	= 1,6,8,9	482	= 1,6,7,8,9
291	= 2,6,9	355	= 2,6,7,9	419	= 2,6,8,9	483	= 2,6,7,8,9
292	= 1,2,6,9	356	= 1,2,6,7,9	420	= 1,2,6,8,9	484	= 1,2,6,7,8,9
293	= 3,6,9	357	= 3,6,7,9	421	= 3,6,8,9	485	= 3,6,7,8,9
294	= 1,3,6,9	358	= 1,3,6,7,9	422	= 1,3,6,8,9	486	= 1,3,6,7,8,9
295	= 2,3,6,9	359	= 2,3,6,7,9	423	= 2,3,6,8,9	487	= 2,3,6,7,8,9
296	= 1,2,3,6,9	360	= 1,2,3,6,7,9	424	= 1,2,3,6,8,9	488	= 1,2,3,6,7,8,9
297	= 4,6,9	361	= 4,6,7,9	425	= 4,6,8,9	489	= 4,6,7,8,9
298	= 1,4,6,9	362	= 1,4,6,7,9	426	= 1,4,6,8,9	490	= 1,4,6,7,8,9
299	= 2,4,6,9	363	= 2,4,6,7,9	427	= 2,4,6,8,9	491	= 2,4,6,7,8,9
300	= 1,2,4,6,9	364	= 1,2,4,6,7,9	428	= 1,2,4,6,8,9	492	= 1,2,4,6,7,8,9
301	= 3,4,6,9	365	= 3,4,6,7,9	429	= 3,4,6,8,9	493	= 3,4,6,7,8,9
302	= 1,3,4,6,9	366	= 1,3,4,6,7,9	430	= 1,3,4,6,8,9	494	= 1,3,4,6,7,8,9
303	= 2,3,4,6,9	367	= 2,3,4,6,7,9	431	= 2,3,4,6,8,9	495	= 2,3,4,6,7,8,9
304	= 1,2,3,4,6,9	368	= 1,2,3,4,6,7,9	432	= 1,2,3,4,6,8,9	496	= 1,2,3,4,6,7,8,9
305	= 5,6,9	369	= 5,6,7,9	433	= 5,6,8,9	497	= 5,6,7,8,9
306	= 1,5,6,9	370	= 1,5,6,7,9	434	= 1,5,6,8,9	498	= 1,5,6,7,8,9
307	= 2,5,6,9	371	= 2,5,6,7,9	435	= 2, 5, 6, 8, 9	499	= 2,5,6,7,8,9
308	= 1,2,5,6,9	372	= 1,2,5,6,7,9	436	= 1,2,5,6,8,9	500	= 1,2,5,6,7,8,9
309	= 3,5,6,9	373	= 3,5,6,7,9	437	= 3,5,6,8,9	501	= 3,5,6,7,8,9
310	= 1,3,5,6,9	374	= 1,3,5,6,7,9	438	= 1,3,5,6,8,9	502	= 1,3,5,6,7,8,9
311	= 2,3,5,6,9	375	= 2,3,5,6,7,9	439	= 2,3,5,6,8,9	503	= 2,3,5,6,7,8,9
312	= 1,2,3,5,6,9	376	= 1,2,3,5,6,7,9	440	= 1,2,3,5,6,8,9	504	= 1,2,3,5,6,7,8,9
313	= 4,5,6,9	377	= 4,5,6,7,9	441	= 4,5,6,8,9	505	= 4,5,6,7,8,9
314	= 1,4,5,6,9	37S	= 1,4,5,6,7,9	442	= 1,4,5,6,8,9	506	= 1,4,5,6,7,8,9
315	= 2,4,5,6,9	379	= 2,4,5,6,7,9	443	= 2,4,5,6,8,9	507	= 2,4,5,6,7,8,9
316	= 1,2,4,5,6,9	380	= 1,2,4,5,6,7,9	444	= 1,2,4,5,6,8,9	508	= 1,2,4,5,6,7,8,9
317	= 3,4,5,6,9	381	= 3,4,5,6,7,9	445	= 3,4,5,6,8,9	509	= 3,4,5,6,7,8,9
318	= 1,3,4,5,6,9	382	= 1,3,4,5,6,7,9	446	= 1,3,4,5,6,8,9	510	= 1,3,4,5,6,7,8,9
319	= 2,3,4,5,6,9	383	= 2,3,4,5,6,7,9	447	= 2,3,4,5,6,8,9	511	= 2,3,4,5,6,7,8,9
320	= 1,2,3,4,5,6,9	384	= 1,2,3,4,5,6,7,9	448	= 1,2,3,4,5,6,8,9	512	= 1,2,3,4,5,6,7,8