

Contents

Warranty and Disclaimer	2
Introduction	3
Physical Dimensions	
Board Layout	4
Usage	
Using the PWM board	5
Setting the start address	6
Using the configuration jumper	7
Typical hookup	8
Setting up the DMX connectors	9
Dimming LED's	10
Motor control	13
Troubleshooting	
Ground, termination, LED	14
Erratic output, misc.	
Using DMX512	
Splitters, terminators	15
Wire type, cable length, connectors	
Diagram of DMX 512 cable routing	17
Mini DIP address settings 1-256	18
257-512	19



Warranty and Disclaimer

Warranty

Northlight Systems warrants this product against defects in materials and workmanship for a period of 1 year.

If the board is defective, we will, at our option, repair or replace the product. We offer a full refund on the purchase price if returned in original condition in less than 30 days.

Return the product with a description of the problem. We will return your item or its replacement using the same shipping method used to ship the product originally.

Disclaimer of Liability

Northlight Systems is not responsible for any special, incidental, or consequential damages resulting for any breach of warranty, or any legal theory, including lost profits, downtime, goodwill, damage to or replacement of equipment or property, and any costs associated with the use of Northlight Systems products described herein.

Northlight Systems has a policy of continually improving our products as new technology becomes available. Northlight Systems reserves the right to make changes and improvements to the specifications of this equipment at any time without notice.

Northlight Systems has made every attempt to ensure that the information in this document is accurate and complete. Northlight Systems assumes no liability for any damages that result from the use of this manual or the equipment it documents. Northlight Systems reserves the right to make changes to this document at any time without notice.

Contact

Northlight Systems
1247 E. Valerie Drive
Tempe, AZ 85281

Voice 480 429-0577
Fax 480 949-2625

8 Channel, Digital PWM board

Features

- Accepts DMX512 digital protocol.
- Outputs 255 pulse widths
- Mini DIP switch address all 512 channels.
- On board voltage regulator.
- Fast 4KHz PWM

SPECS

Input Signal: Northlight PWM08 board accepts DMX512 - 1990 as specified by USITT. The PWM8 board can receive data at the full rate.

Output: Output is 8 PWM channels capable of 255 discrete widths spanning 0 to 100 % duty cycle.
The PWM rate 4K Hz.

Address switch: Mini DIP switches.

Power requirements: 8 to 18 volts DC @ 100 mA. Max. for controller board.

Output power is separate and dependent on the load.

LED Indicators:

Green DMX signal present LED.

Board connections: All connections are made with mini screw terminals. See drawing for connector locations.

Physical Dimensions

3.75" L X 2.75" W +/- .20"

The **DMX input** pin numbers correspond to the XLR pin numbers.

The **Common** connector is signal ground – not earth ground.

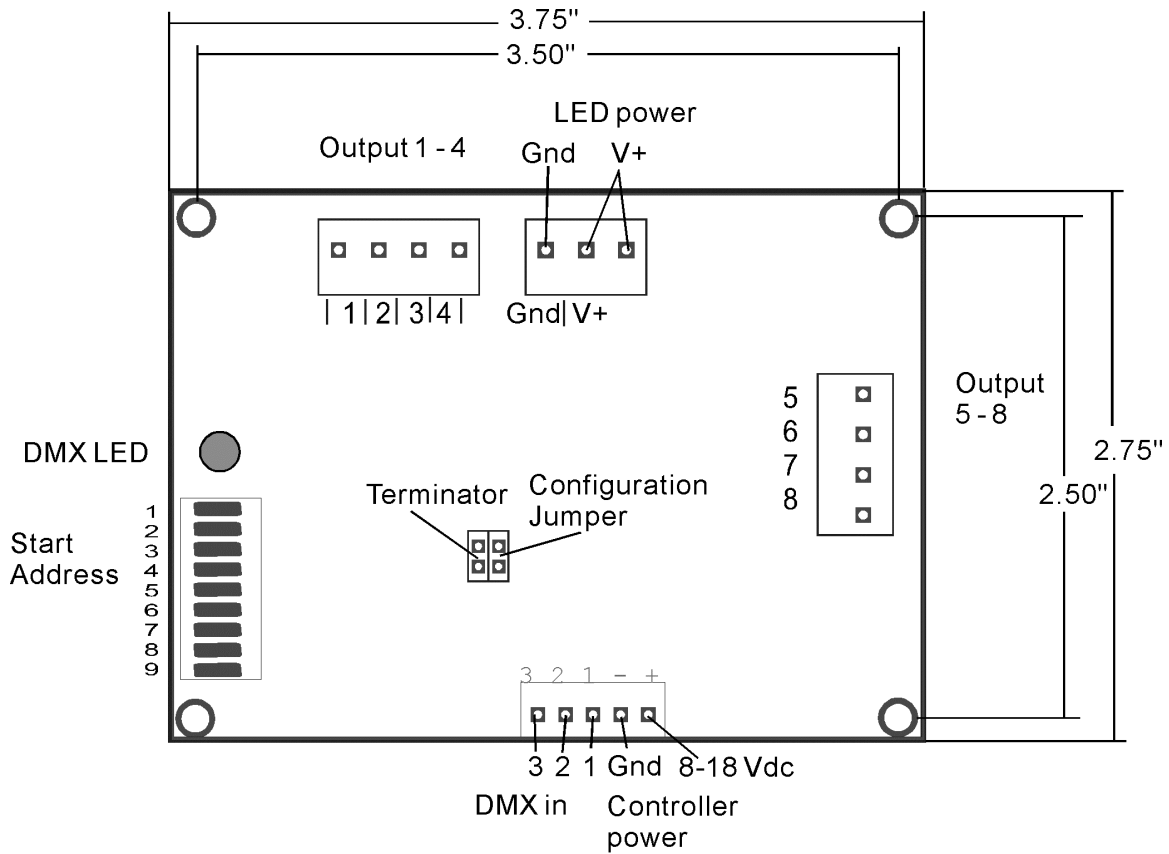

Using the PWM08 board

Board Power Input

8 to 18 volts DC @ 100 mA. MAX current, for the board. On average the current consumption is around 60 mA.

Load Power Input

The load power is a separate connector. The voltage can be 5 – 24 VDC.

Ground

The signal ground connector is the common signal ground – not earth ground.

DMX512 In

The DMX input pin numbers correspond to the XLR pin numbers.

Pin 1 is signal ground, not earth ground

Pin 2 is DMX512 -

Pin 3 is DMX512 +

Address Switch

The individual switches are numbered 1 – 9, left to right.

The address switch is scanned by the controller around every 30 seconds. There is a noticeable delay after the switches are set, until the change is seen.

Setting the address for DMX512

Set the starting address to the first in a group of 8. The address is entered on the DIP switches in standard binary code starting with 1. See the chart of all 512 address switch positions at the back of this manual.

Using the configuration jumper

There is 1 configuration jumpers on the board.

J1 – Determines the output in the event of DMX signal loss.

Open(no jumper) - When the DMX signal is lost, the output will be zero.

Closed(jumper in place) – When the DMX signal is lost the board will hold and continue to output the last valid data.

Setting up the DMX connectors

The current DMX512 standards require one to provide passive loop through connectors.

The specific description is below:

Secondary data link - passive loop through ports

Devices containing two DMX512 ports, one for receive and one for transmit, ..., shall provide a direct passive link for all pins between the two ports.

Equipment designers are encouraged to provide passive loop through on Pins 4 and 5 whenever possible, even if not required.

The drawing below shows a typical installation.

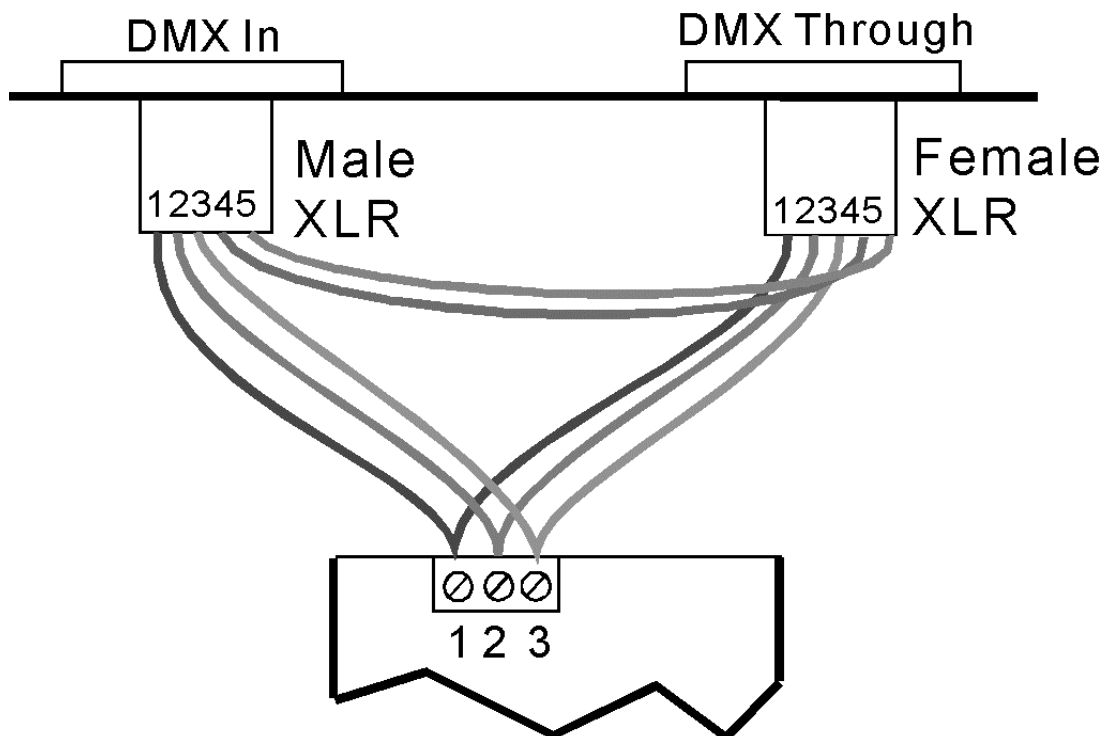

Using LED's with the PWM board

LED's are current controlled devices. The more current passing through the LED the brighter it is. Standard LED's usually require 15 to 20 milliAmps(mA) to reach full brightness. High efficiency LED's may only require 5-10 mA. Blue and white LED's often require 30-50 mA to reach full brightness.

A minimum voltage is required before a LED will illuminate. This is referred to as "VF" or the "forward voltage. On a standard LED the forward voltage usually varies from 1.2 to 2.2 volts. Blue and white LED's usually have a VF of 3.3v.

A resistor must be used in series with the LED to prevent excessive current flow. The value of the resistor is dependent on the power supply voltage, the amount of current required and the VF of the LED.

To calculate the resistor use the formula below:

$$V_s - V_f / I_f$$

Where V_s = power supply voltage

V_f is the forward voltage of the LED

I_f is the desired current.

Example: Red LED with forward voltage of 2VDC at 20 mA with 10 volt supply

$$10V - 2V = 8V$$

$$8V / .02Amps = 400$$

The correct resistor = 400 Ohms

Resistors also have a watt rating. This is the total power the resistor can handle without overheating.

Ohms law states the formula for watts is $I(\text{amps}) \times V(\text{volts}) = \text{Watts}$.

In the example, $.02Amps \times 2\text{volts}(V_f) = .04 \text{ watts}$. A standard $\frac{1}{4}$ watt resistor is fine for a single LED.

When using many LED's in an array a larger wattage resistor will probably be needed.

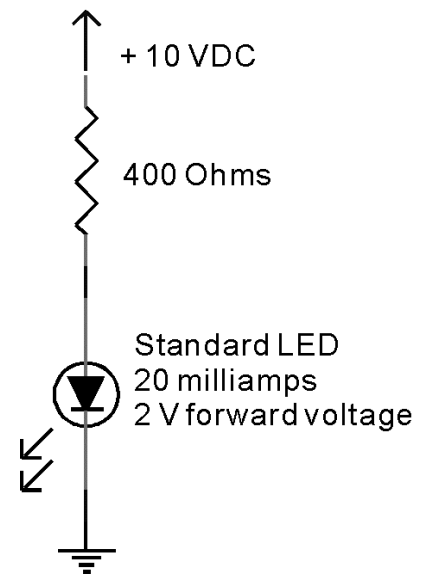

Luxeon Star Example

A standard Luxeon star is rated at 3.3VDC V_f at 350 milliamps.

Example with 12 vdc power supply.

$$12 - 3.3 = 8.7 \text{ volts}$$

$$8.7 / .350 = 2.48 \text{ Ohms}$$

$$8.7 \times .350 = 3.04$$

In this example a 2.5 Ohm 3 watt resistor

A 5 watt metal film resistor is common.

Multi-LED circuits

If many LED's need to be driven on a single output channel this can be done by wiring the LED's in series.

Wiring LED's in series requires the supply voltage to be higher than the sum of the individual LED forward voltages. Series wired LED's consume a minimum amount of current, but there are limits to the number of LED that can be wired in series.

It is possible to use a parallel and series arrangement as shown in the drawing below.

In the example shown there are 3 series LED in 3 parallel arrangement.

Example using blue LED:

Each LED has a forward voltage of 3.3 VDC.

Each LED requires 30 milliamps

The supply voltage has to be higher than

$3 \times 3.3\text{V} = 9.9\text{ VDC}$ minimum

it should supply more than 9×30 milliamps for 270 milliamps total

The calculate the value for each resistor

With a 12 volt supply

$V_S = 12\text{ VDC}$

$12V_s - 9.9V_f = 2.1V$

$2.1V / .09A = 23.3\text{ Ohms}$

27 Ohms is a common value

$\text{watt} = 2.1V \times .09A = .189W$

a standard $\frac{1}{4}$ watt resistor will be fine for this example.

3 – $\frac{1}{4}$ watt, 23 or 24 Ohm resistors will work for 9 Blue LED.

4 Lead RGB LED

4 lead RGB LED should be common anode type.

They must be wired in parallel.

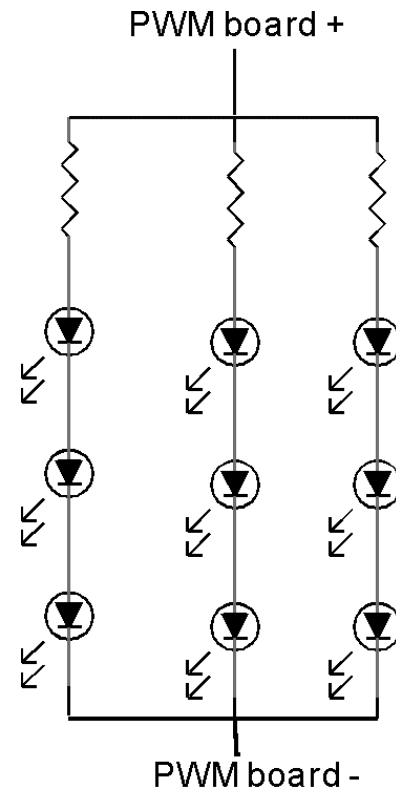

Using DC Motors with the PWM board

DC motors usually will not require a series resistor like the LED example above. The Voltage and current requirements are usually higher than LED and require a more robust power supply.

Even small motors can draw considerable current when under load or in a stall condition.

It is best to use a separate power supply for the controller power and the motor power.

There is a place for a “flyback” diode on the PC board. The flyback diode is NOT optional. If a motor is used the proper diode must be on the board or the MOSFET will be destroyed.

A standard 1N400X diode will not work in this application.

At least a Schottkey diode such 1N518 or other fast diode must be used. It should be capable of 1 amp or more.

A brush DC motor will generate considerable EMI. A .1 to .01 uf, capacitor should be soldered directly to the terminals of the motor.

When using motors a heatsink may be required on the MOSFET.

Equivalent Circuit

The board circuit is designed to sink current. The + terminals on the output terminals are connected to the load V+. This arrangement is a common anode circuit.

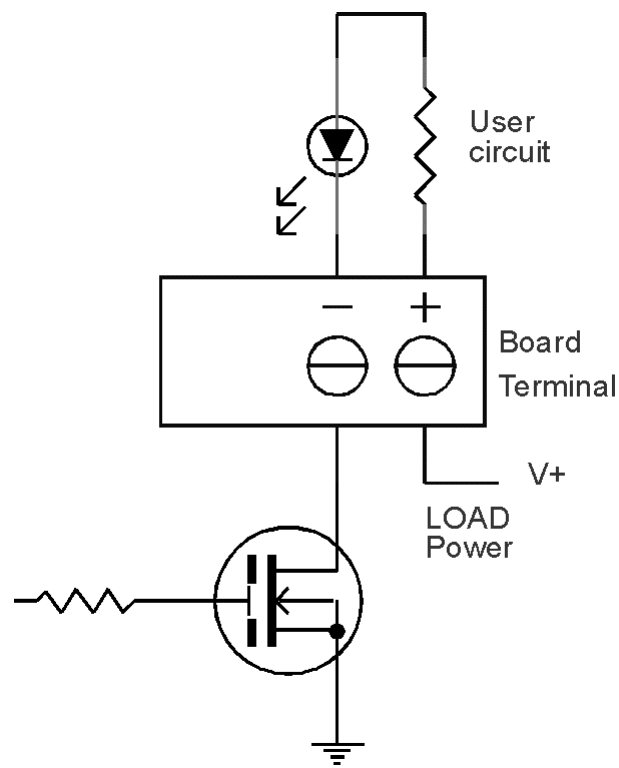

Termination

A common problem with DMX systems is improper termination. A simple terminator consists of a 120 Ohm resistor connected across pins 2-3 of the DMX signal

The PWM board provides an on board terminator using standard square pin connectors on .10" centers.

A toggle switch can be placed across the terminals for convenient front panel terminator selection.

The switch should be labeled "In" and "Out".

The termination resistor should only be in when the decoder is the last device on the DMX link.



Trouble shooting

Basically the board is plug and play. When all connections are properly made, an variable pulse, proportional to the input signal will be present at the output pins.

Signal Ground/common: On the board, there is NO connection between chassis/earth ground and Signal/common ground. Do not install one.

On the DMX data cable, there is NO connection between the shield/XLR shell earth ground and the signal/common ground. Do not connect these together.

Termination – DMX mode If the PWM08 board is the last one on the DMX link a jumper for the terminating resistor can be installed on the PC board.

It is possible to “over terminate”. In other words make sure there is only 1 terminator on the end of the DMX line. Some devices have internal terminators, double check the settings.

No output:

DMX512 Check the signal wires as noted above.

Be sure the address is set to a valid address. The PWM08 start address should not be higher than the highest address received.

Erratic output: This problem can be hard to track down.

First check the input signal integrity. There should be signal present on both Data lines for DMX512. Reverse the connections.

Misc: Good solid connections are a must. The mini screw terminals provide good connections. However the screws can be stripped by over tightening. DMX512 signal wires should be twisted together all the way to the connector. It is recommended that a separate transformer be used to power the PWM08 board. Occasionally unexpected problems can occur if power is “borrowed” from another source. Small wall wart transformers work well for this application.

Using DMX512

DMX 512 is a digital communications protocol that specifies a set of requirements for transmitting and receiving digital signals between lighting controllers and dimmers. There are 2 main components to this spec. The Data Protocol is the meaning of the bits and bytes that are transmitted. Northlight's Decoder is compliant with the full requirements of the Data Protocol. There is a certain amount of flexibility in the signal timing, Northlight's Decoder is capable of receiving data at the full data rate specified.

The other component of DMX512 is the Electrical Specifications. The hardware electrical specs are listed in EIA-485, commonly referred to as the RS-485 specs. The RS-485 standard, specifies only the electrical characteristics of the driver and the receiver to be used at the line interface. Northlight's Decoder is compliant with RS-485. Each Decoder represents less than 1 node load to the system.

RS485 is a data transmission system using balanced differential signals. That is 2 signal wires and signal ground. 3 wires are required.

Splitters/Repeaters

Isolation between the console and dimmers is sometimes required to prevent signal degradation and protect devices from damaging voltages on the control cable. Optically isolated splitters help avoid these problems.

Each DMX512 output can drive up to 32 devices. If there are more devices on the line, a "repeater" or "booster" is required.

Some cheap devices are not fully compliant and actually represent a load equivalent to 2 or more devices.

Long or improper cables, electrically noisy environment (generators, motors) and improper use of passive "Y" splitters all contribute to DMX signal degradation. A repeater/booster may help to solve these problems.

Why ask WYE?

Wye(Y) splitters are NOT recommended for DMX512 systems. Wye splitters are simply a male inline XLR connector, parallel wired to 2 female inline XLR's. While convenient, Wye splitters cause unwanted signal reflections and possible ground loops, leading to signal degradation.

The best layout for DMX systems is a Daisy chain configuration, where the signal cable jumps from one device to the next, with no branching. Each chain can have up to 32 devices on it. When using an isolated splitter, each outputs can be a separate DMX daisy chain.

Termination

A common problem with DMX systems is improper termination.

A simple terminator consists of a 120 Ohm resistor connected across pins 2-3 of the DMX signal. More complex terminators utilize voltage spike protection and bi-color LEDs to indicate signal integrity.

Terminators are an impedance matching circuit required to damp signals that “reflect “ from the end of an improperly terminated cable, causing signal degradation under certain conditions.

On devices that have a DMX thru , a male XLR connector with terminating resistor connected across pins 2-3 and installed on the DMX thru connector will suffice. Some devices with isolated outputs will not use a terminator on the DMX out. These usually have an internal terminator that is selected with a switch.

Wire Type

There is a difference between microphone cable and “Data” cable. Sure you can get away with mic. cable for short runs in many situations. However on longer runs or marginal situations mic. cable will let you down. You may have random errors or the system won’t work at all. It comes down to insurance. If you want to insure the most reliable DMX signal distribution you need the most appropriate wire for the job. DMX512 requires wire suitable for RS-485, there is no way to get around that.

Twisted-pair cable is the most common wire type. You can use a range of wire gauges, most frequently use 22 – 24 AWG. The characteristic impedance of the cable should be 100 to 120 Ohms.

Some other requirements are, at least 1 twisted pair plus ground and shield. It should have low capacitance and overall braid and foil shield.

Data Rate VS Cable Length

At 250K bits per second the max cable length is about 1000 ft for DMX512 in good conditions.

Connectors

DMX512 protocol specifies that 5 pin XLR connectors be used. Female on the transmitter and male on the receiver.

When a 3 pin XLR is used it is wired the same as the first 3 pins on the 5 pin XLR.

<u>PIN</u>	<u>WIRE</u>	<u>SIGNAL</u>
1	shield	ground/return
2	signal	data compliment (-)
3	signal	data true (+)
4	signal	spare data compliment (-)
5	signal conductor	spare data true (+)

Conductors 2/3 and 4/5 should be twisted together.

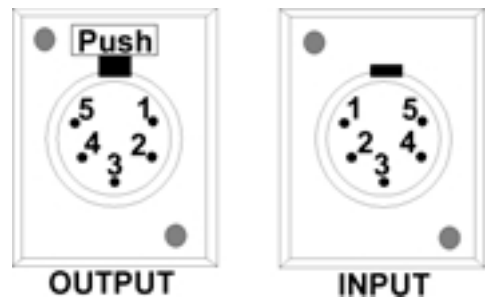

Typical DMX signal routing

Simple setup

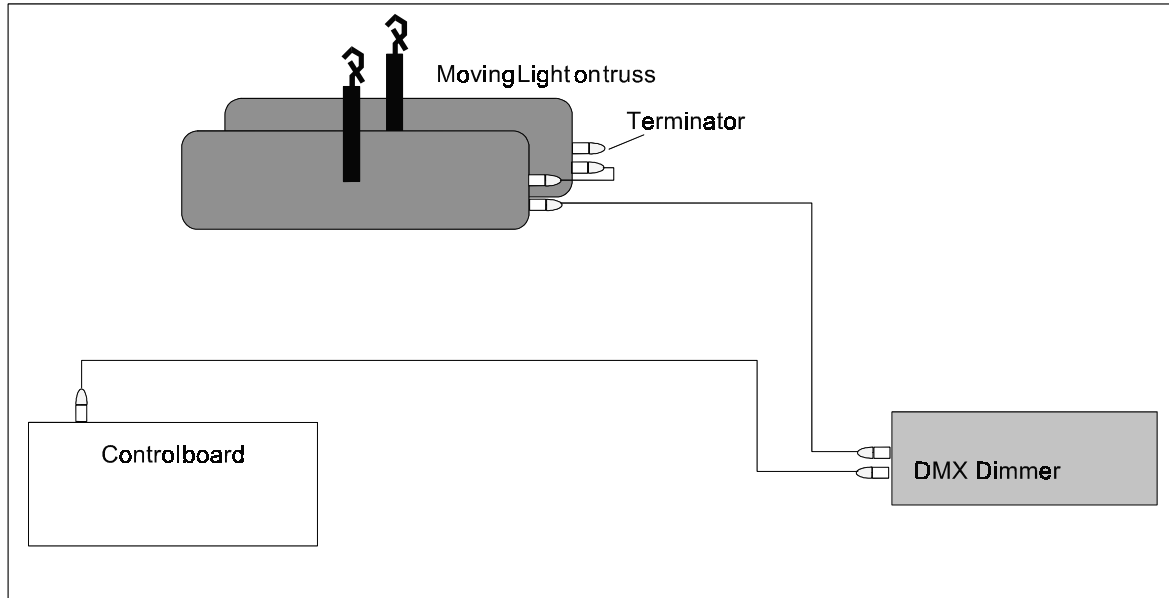

A more complicated setup. The Isolated splitter greatly simplifies cable routing and keeps individual runs short.

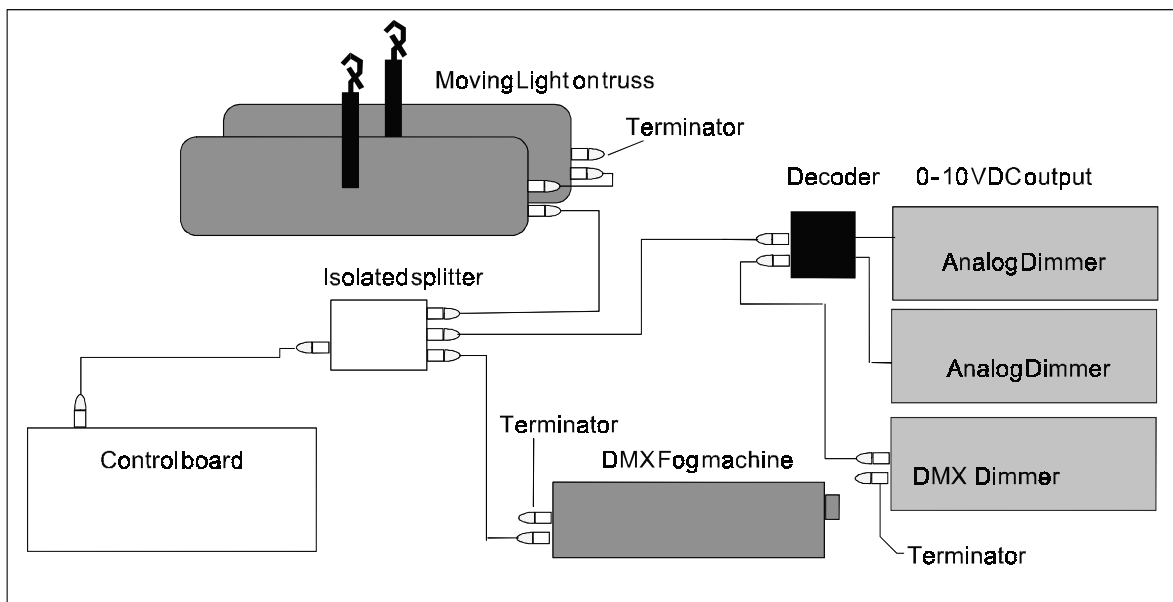

NORHLIGHT SYSTEMS

Address - Switches

1 = 1
 2 = 2
 3 = 1, 2
 4 = 3
 5 = 1, 3
 6 = 2, 3
 7 = 1, 2, 3
 8 = 4
 9 = 1, 4
 10 = 2, 4
 11 = 1, 2, 4
 12 = 3, 4
 13 = 1, 3, 4
 14 = 2, 3, 4
 15 = 1, 2, 3, 4
 16 = 5
 17 = 1, 5
 18 = 2, 5
 19 = 1, 2, 5
 20 = 3, 5
 21 = 1, 3, 5
 22 = 2, 3, 5
 23 = 1, 2, 3, 5
 24 = 4, 5
 25 = 1, 4, 5
 26 = 2, 4, 5
 27 = 1, 2, 4, 5
 28 = 3, 4, 5
 29 = 1, 3, 4, 5
 30 = 2, 3, 4, 5
 31 = 1, 2, 3, 4, 5
 32 = 6
 33 = 1, 6
 34 = 2, 6
 35 = 1, 2, 6
 36 = 3, 6
 37 = 1, 3, 6
 38 = 2, 3, 6
 39 = 1, 2, 3, 6
 40 = 4, 6
 41 = 1, 4, 6
 42 = 2, 4, 6
 43 = 1, 2, 4, 6
 44 = 3, 4, 6
 45 = 1, 3, 4, 6
 46 = 2, 3, 4, 6
 47 = 1, 2, 3, 4, 6
 48 = 5, 6
 49 = 1, 5, 6
 50 = 2, 5, 6
 51 = 1, 2, 5, 6
 52 = 3, 5, 6
 53 = 1, 3, 5, 6
 54 = 2, 3, 5, 6
 55 = 1, 2, 3, 5, 6
 56 = 4, 5, 6
 57 = 1, 4, 5, 6
 58 = 2, 4, 5, 6
 59 = 1, 2, 4, 5, 6
 60 = 3, 4, 5, 6
 61 = 1, 3, 4, 5, 6
 62 = 2, 3, 4, 5, 6

63 = 1, 2, 3, 4, 5, 6

Address - switches

64 = 7
 65 = 1, 7
 66 = 2, 7
 67 = 1, 2, 7
 68 = 3, 7
 69 = 1, 3, 7
 70 = 2, 3, 7
 71 = 1, 2, 3, 7
 72 = 4, 7
 73 = 1, 4, 7
 74 = 2, 4, 7
 75 = 1, 2, 4, 7
 76 = 3, 4, 7
 77 = 1, 3, 4, 7
 78 = 2, 3, 4, 7
 79 = 1, 3, 4, 7
 80 = 5, 7
 81 = 1, 5, 7
 82 = 2, 5, 7
 83 = 1, 2, 5, 7
 84 = 3, 5, 7
 85 = 1, 3, 5, 7
 86 = 2, 3, 5, 7
 87 = 1, 2, 3, 5, 7
 88 = 4, 5, 7
 89 = 1, 4, 5, 7
 90 = 2, 4, 5, 7
 91 = 1, 2, 4, 5, 7
 92 = 3, 4, 5, 7
 93 = 1, 3, 4, 5, 7
 94 = 2, 3, 4, 5, 7
 95 = 1, 2, 3, 4, 5, 7
 96 = 6, 7
 97 = 1, 6, 7
 98 = 2, 6, 7
 99 = 1, 2, 6, 7
 100 = 3, 6, 7
 101 = 1, 3, 6, 7
 102 = 2, 3, 6, 7
 103 = 1, 2, 3, 6, 7
 104 = 4, 6, 7
 105 = 1, 4, 6, 7
 106 = 2, 4, 6, 7
 107 = 1, 2, 4, 6, 7
 108 = 3, 4, 6, 7
 109 = 1, 3, 4, 6, 7
 110 = 2, 3, 4, 6, 7
 111 = 1, 2, 3, 4, 6, 7
 112 = 5, 6, 7
 113 = 1, 5, 6, 7
 114 = 2, 5, 6, 7
 115 = 1, 2, 5, 6, 7
 116 = 3, 5, 6, 7
 117 = 1, 3, 5, 6, 7
 118 = 2, 3, 5, 6, 7
 119 = 1, 2, 3, 5, 6, 7
 120 = 4, 5, 6, 7
 121 = 1, 4, 5, 6, 7
 122 = 2, 4, 5, 6, 7
 123 = 1, 2, 4, 5, 6, 7
 124 = 3, 4, 5, 6, 7
 125 = 1, 3, 4, 5, 6, 7

126 = 2, 3, 4, 5, 6, 7

Address - switches

127 = 1, 2, 3, 4, 5, 6, 7
 128 = 8
 129 = 1, 8
 130 = 2, 8
 131 = 1, 2, 8
 132 = 3, 8
 133 = 1, 3, 8
 134 = 2, 3, 8
 135 = 1, 2, 3, 8
 136 = 4, 8
 137 = 1, 4, 8
 138 = 2, 4, 8
 139 = 1, 2, 4, 8
 140 = 3, 4, 8
 141 = 1, 3, 4, 8
 142 = 2, 3, 4, 8
 143 = 1, 2, 3, 4, 8
 144 = 5, 8
 145 = 1, 5, 8
 146 = 2, 5, 8
 147 = 1, 2, 5, 8
 148 = 3, 5, 8
 149 = 1, 3, 5, 8
 150 = 2, 3, 5, 8
 151 = 1, 2, 3, 5, 8
 152 = 4, 5, 8
 153 = 1, 4, 5, 8
 154 = 2, 4, 5, 8
 155 = 1, 2, 4, 5, 8
 156 = 3, 4, 5, 8
 157 = 1, 3, 4, 5, 8
 158 = 2, 3, 4, 5, 8
 159 = 1, 2, 3, 4, 5, 8
 160 = 6, 8
 161 = 1, 6, 8
 162 = 2, 6, 8
 163 = 1, 2, 6, 8
 164 = 3, 6, 8
 165 = 1, 3, 6, 8
 166 = 2, 3, 6, 8
 167 = 1, 2, 3, 6, 8
 168 = 4, 6, 8
 169 = 1, 4, 6, 8
 170 = 2, 4, 6, 8
 171 = 1, 2, 4, 6, 8
 172 = 3, 4, 6, 8
 173 = 1, 3, 4, 6, 8
 174 = 2, 3, 4, 6, 8
 175 = 1, 2, 3, 4, 6, 8
 176 = 5, 6, 8
 177 = 1, 5, 6, 8
 178 = 2, 5, 6, 8
 179 = 1, 2, 5, 6, 8
 180 = 3, 5, 6, 8
 181 = 1, 3, 5, 6, 8
 182 = 2, 3, 5, 6, 8
 183 = 1, 2, 3, 5, 6, 8
 184 = 4, 5, 6, 8
 185 = 1, 4, 5, 6, 8
 186 = 2, 4, 5, 6, 8
 187 = 1, 2, 4, 5, 6, 8
 188 = 3, 4, 5, 6, 8

189 = 1, 3, 4, 5, 6, 8

Address - switches

190 = 2, 3, 4, 5, 6, 8
 191 = 1, 2, 3, 4, 5, 6, 8
 192 = 7, 8
 193 = 1, 7, 8
 194 = 2, 7, 8
 195 = 1, 2, 7, 8
 196 = 3, 7, 8
 197 = 1, 3, 7, 8
 198 = 2, 3, 7, 8
 199 = 1, 2, 3, 7, 8
 200 = 4, 7, 8
 201 = 1, 4, 7, 8
 202 = 2, 4, 7, 8
 203 = 1, 2, 4, 7, 8
 204 = 3, 4, 7, 8
 205 = 1, 3, 4, 7, 8
 206 = 2, 3, 4, 7, 8
 207 = 1, 2, 3, 4, 7, 8
 208 = 5, 7, 8
 209 = 1, 5, 7, 8
 210 = 2, 5, 7, 8
 211 = 1, 2, 5, 7, 8
 212 = 3, 5, 7, 8
 213 = 1, 3, 5, 7, 8
 214 = 2, 3, 5, 7, 8
 215 = 1, 2, 3, 5, 7, 8
 216 = 4, 5, 7, 8
 217 = 1, 4, 5, 7, 8
 218 = 2, 4, 5, 7, 8
 219 = 1, 2, 4, 5, 7, 8
 220 = 3, 4, 5, 7, 8
 221 = 1, 3, 4, 5, 7, 8
 222 = 2, 3, 4, 5, 7, 8
 223 = 1, 2, 3, 4, 5, 7, 8
 224 = 6, 7, 8
 225 = 1, 6, 7, 8
 226 = 2, 6, 7, 8
 227 = 1, 2, 6, 7, 8
 228 = 3, 6, 7, 8
 229 = 1, 3, 6, 7, 8
 230 = 2, 3, 6, 7, 8
 231 = 1, 2, 3, 6, 7, 8
 232 = 4, 6, 7, 8
 233 = 1, 4, 6, 7, 8
 234 = 2, 4, 6, 7, 8
 235 = 1, 2, 4, 6, 7, 8
 236 = 3, 4, 6, 7, 8
 237 = 1, 3, 4, 6, 7, 8
 238 = 2, 3, 4, 6, 7, 8
 239 = 1, 2, 3, 4, 6, 7, 8
 240 = 5, 6, 7, 8
 241 = 1, 5, 6, 7, 8
 242 = 2, 5, 6, 7, 8
 243 = 1, 2, 5, 6, 7, 8
 244 = 3, 5, 6, 7, 8
 245 = 1, 3, 5, 6, 7, 8
 246 = 2, 3, 5, 6, 7, 8
 247 = 1, 2, 3, 5, 6, 7, 8
 248 = 4, 5, 6, 7, 8
 249 = 1, 4, 5, 6, 7, 8
 250 = 2, 4, 5, 6, 7, 8
 251 = 1, 2, 4, 5, 6, 7, 8

252 = 3, 4, 5, 6, 7, 8	323 = 1, 2, 7, 9	394 = 2, 4, 8, 9	465 = 1, 5, 7, 8, 9
Address - switches	Address - switches	Address - switches	Address - switches
253 = 1, 3, 4, 5, 6, 7, 8	324 = 3, 7, 9	395 = 1, 2, 4, 8, 9	466 = 2, 5, 7, 8, 9
254 = 2, 3, 4, 5, 6, 7, 8	325 = 1, 3, 7, 9	396 = 3, 4, 8, 9	467 = 1, 2, 5, 7, 8, 9
255 = 1, 2, 3, 4, 5, 6, 7, 8	326 = 2, 3, 7, 9	397 = 1, 3, 4, 8, 9	468 = 3, 5, 7, 8, 9
256 = 9	327 = 1, 2, 3, 7, 9	398 = 2, 3, 4, 8, 9	469 = 1, 3, 5, 7, 8, 9
257 = 1, 9	328 = 4, 7, 9	399 = 1, 2, 3, 4, 8, 9	470 = 2, 3, 5, 7, 8, 9
258 = 2, 9	329 = 1, 4, 7, 9	400 = 5, 8, 9	471 = 1, 2, 3, 5, 7, 8, 9
259 = 1, 2, 9	330 = 2, 4, 7, 9	401 = 1, 5, 8, 9	472 = 4, 5, 7, 8, 9
260 = 3, 9	331 = 1, 2, 4, 7, 9	402 = 2, 5, 8, 9	473 = 1, 4, 5, 7, 8, 9
261 = 1, 3, 9	332 = 3, 4, 7, 9	403 = 1, 2, 5, 8, 9	474 = 2, 4, 5, 7, 8, 9
262 = 2, 3, 9	333 = 1, 3, 4, 7, 9	404 = 3, 5, 8, 9	475 = 1, 2, 4, 5, 7, 8, 9
263 = 1, 2, 3, 9	334 = 2, 3, 4, 7, 9	405 = 1, 3, 5, 8, 9	476 = 3, 4, 5, 7, 8, 9
264 = 4, 9	335 = 1, 2, 3, 4, 7, 9	406 = 2, 3, 5, 8, 9	477 = 1, 3, 4, 5, 7, 8, 9
265 = 1, 4, 9	336 = 5, 7, 9	407 = 1, 2, 3, 5, 8, 9	478 = 2, 3, 4, 5, 7, 8, 9
266 = 2, 4, 9	337 = 1, 5, 7, 9	408 = 4, 5, 8, 9	479 = 1, 2, 3, 4, 5, 7, 8, 9
267 = 1, 2, 4, 9	338 = 2, 5, 7, 9	409 = 1, 4, 5, 8, 9	480 = 6, 7, 8, 9
268 = 3, 4, 9	339 = 1, 2, 5, 7, 9	410 = 2, 4, 5, 8, 9	481 = 1, 6, 7, 8, 9
269 = 1, 3, 4, 9	340 = 3, 5, 7, 9	411 = 1, 2, 4, 5, 8, 9	482 = 2, 6, 7, 8, 9
270 = 2, 3, 4, 9	341 = 1, 3, 5, 7, 9	412 = 3, 4, 5, 8, 9	483 = 1, 2, 6, 7, 8, 9
271 = 1, 2, 3, 4, 9	342 = 2, 3, 5, 7, 9	413 = 1, 3, 4, 5, 8, 9	484 = 3, 6, 7, 8, 9
272 = 5, 9	343 = 1, 2, 3, 5, 7, 9	414 = 2, 3, 4, 5, 8, 9	485 = 1, 3, 6, 7, 8, 9
273 = 1, 5, 9	344 = 4, 5, 7, 9	415 = 1, 2, 3, 4, 5, 8, 9	486 = 2, 3, 6, 7, 8, 9
274 = 2, 5, 9	345 = 1, 4, 5, 7, 9	416 = 6, 8, 9	487 = 1, 2, 3, 6, 7, 8, 9
275 = 1, 2, 5, 9	346 = 2, 4, 5, 7, 9	417 = 1, 6, 8, 9	488 = 4, 6, 7, 8, 9
276 = 3, 5, 9	347 = 1, 2, 4, 5, 7, 9	418 = 2, 6, 8, 9	489 = 1, 4, 6, 7, 8, 9
277 = 1, 3, 5, 9	348 = 3, 4, 5, 7, 9	419 = 1, 2, 6, 8, 9	490 = 2, 4, 6, 7, 8, 9
278 = 2, 3, 5, 9	349 = 1, 3, 4, 5, 7, 9	420 = 3, 6, 8, 9	491 = 1, 2, 4, 6, 7, 8, 9
279 = 1, 2, 3, 5, 9	350 = 2, 3, 4, 5, 7, 9	421 = 1, 3, 6, 8, 9	492 = 3, 4, 6, 7, 8, 9
280 = 4, 5, 9	351 = 1, 2, 3, 4, 5, 7, 9	422 = 2, 3, 6, 8, 9	493 = 1, 3, 4, 6, 7, 8, 9
281 = 1, 4, 5, 9	352 = 6, 7, 9	423 = 1, 2, 3, 6, 8, 9	494 = 2, 3, 4, 6, 7, 8, 9
282 = 2, 4, 5, 9	353 = 1, 6, 7, 9	424 = 4, 6, 8, 9	495 = 1, 2, 3, 4, 6, 7, 8, 9
283 = 1, 2, 4, 5, 9	354 = 2, 6, 7, 9	425 = 1, 4, 6, 8, 9	496 = 5, 6, 7, 8, 9
284 = 3, 4, 5, 9	355 = 1, 2, 6, 7, 9	426 = 2, 4, 6, 8, 9	497 = 1, 5, 6, 7, 8, 9
285 = 1, 3, 4, 5, 9	356 = 3, 6, 7, 9	427 = 1, 2, 4, 6, 8, 9	498 = 2, 5, 6, 7, 8, 9
286 = 2, 3, 4, 5, 9	357 = 1, 3, 6, 7, 9	428 = 3, 4, 6, 8, 9	499 = 1, 2, 5, 6, 7, 8, 9
287 = 1, 2, 3, 4, 5, 9	358 = 2, 3, 6, 7, 9	429 = 1, 3, 4, 6, 8, 9	500 = 3, 5, 6, 7, 8, 9
288 = 6, 9	359 = 1, 2, 3, 6, 7, 9	430 = 2, 3, 4, 6, 8, 9	501 = 1, 3, 5, 6, 7, 8, 9
289 = 1, 6, 9	360 = 4, 6, 7, 9	431 = 1, 2, 3, 4, 6, 8, 9	502 = 2, 3, 5, 6, 7, 8, 9
290 = 2, 6, 9	361 = 1, 4, 6, 7, 9	432 = 5, 6, 8, 9	503 = 1, 2, 3, 5, 6, 7, 8, 9
291 = 1, 2, 6, 9	362 = 2, 4, 6, 7, 9	433 = 1, 5, 6, 8, 9	504 = 4, 5, 6, 7, 8, 9
292 = 3, 6, 9	363 = 1, 2, 4, 6, 7, 9	434 = 2, 5, 6, 8, 9	505 = 1, 4, 5, 6, 7, 8, 9
293 = 1, 3, 6, 9	364 = 3, 4, 6, 7, 9	435 = 1, 2, 5, 6, 8, 9	506 = 2, 4, 5, 6, 7, 8, 9
294 = 2, 3, 6, 9	365 = 1, 3, 4, 6, 7, 9	436 = 3, 5, 6, 8, 9	507 = 1, 2, 4, 5, 6, 7, 8, 9
295 = 1, 2, 3, 6, 9	366 = 2, 3, 4, 6, 7, 9	437 = 1, 3, 5, 6, 8, 9	508 = 3, 4, 5, 6, 7, 8, 9
296 = 4, 6, 9	367 = 1, 2, 3, 4, 6, 7, 9	438 = 2, 3, 5, 6, 8, 9	509 = 1, 3, 4, 5, 6, 7, 8, 9
297 = 1, 4, 6, 9	368 = 5, 6, 7, 9	439 = 1, 2, 3, 5, 6, 8, 9	510 = 2, 3, 4, 5, 6, 7, 8, 9
298 = 2, 4, 6, 9	369 = 1, 5, 6, 7, 9	440 = 4, 5, 6, 8, 9	511 = 1, 2, 3, 4, 5, 6, 7, 8, 9
299 = 1, 2, 4, 6, 9	370 = 2, 5, 6, 7, 9	441 = 1, 4, 5, 6, 8, 9	512 = 0
300 = 3, 4, 6, 9	371 = 1, 2, 5, 6, 7, 9	442 = 2, 4, 5, 6, 8, 9	
301 = 1, 3, 4, 6, 9	372 = 3, 5, 6, 7, 9	443 = 1, 2, 4, 5, 6, 8, 9	
302 = 2, 3, 4, 6, 9	373 = 1, 3, 5, 6, 7, 9	444 = 3, 4, 5, 6, 8, 9	
303 = 1, 2, 3, 4, 6, 9	374 = 2, 3, 5, 6, 7, 9	445 = 1, 3, 4, 5, 6, 8, 9	
304 = 5, 6, 9	375 = 1, 2, 3, 5, 6, 7, 9	446 = 2, 3, 4, 5, 6, 8, 9	
305 = 1, 5, 6, 9	376 = 4, 5, 6, 7, 9	447 = 1, 2, 3, 4, 5, 6, 8, 9	
306 = 2, 5, 6, 9	377 = 1, 4, 5, 6, 7, 9	448 = 7, 8, 9	
307 = 1, 2, 5, 6, 9	378 = 2, 4, 5, 6, 7, 9	449 = 1, 7, 8, 9	
308 = 3, 5, 6, 9	379 = 1, 2, 4, 5, 6, 7, 9	450 = 2, 7, 8, 9	
309 = 1, 3, 5, 6, 9	380 = 3, 4, 5, 6, 7, 9	451 = 1, 2, 7, 8, 9	
310 = 2, 3, 5, 6, 9	381 = 1, 3, 4, 5, 6, 7, 9	452 = 3, 7, 8, 9	
311 = 1, 2, 3, 5, 6, 9	382 = 2, 3, 4, 5, 6, 7, 9	453 = 1, 3, 7, 8, 9	
312 = 4, 5, 6, 9	383 = 1, 2, 3, 4, 5, 6, 7, 9	454 = 2, 3, 7, 8, 9	
313 = 1, 4, 5, 6, 9	384 = 8, 9	455 = 1, 2, 3, 7, 8, 9	
314 = 2, 4, 5, 6, 9	385 = 1, 8, 9	456 = 4, 7, 8, 9	
315 = 1, 2, 4, 5, 6, 9	386 = 2, 8, 9	457 = 1, 4, 7, 8, 9	
316 = 3, 4, 5, 6, 9	387 = 1, 2, 8, 9	458 = 2, 4, 7, 8, 9	
317 = 1, 3, 4, 5, 6, 9	388 = 3, 8, 9	459 = 1, 2, 4, 7, 8, 9	
318 = 2, 3, 4, 5, 6, 9	389 = 1, 3, 8, 9	460 = 3, 4, 7, 8, 9	
329 = 1, 2, 3, 4, 5, 6, 9	390 = 2, 3, 8, 9	461 = 1, 3, 4, 7, 8, 9	
320 = 7, 9	391 = 1, 2, 3, 8, 9	462 = 2, 3, 4, 7, 8, 9	
321 = 1, 7, 9	392 = 4, 8, 9	463 = 1, 2, 3, 4, 7, 8, 9	
322 = 2, 7, 9	393 = 1, 4, 8, 9	464 = 5, 7, 8, 9	